



ELECTRIC SCISSOR LIFT

AS0812 / AS1012 / AS1212
(AS2646 / AS3246 / AS4046)

HIGHLIGHTS

LGMG hydraulic motor drive scissor lifts offer industry leading reliability and simple design. They can be applied to various construction sites, maintenance job sites and other applications, both indoor and outdoor. The wide range product line from 5.8m to 13.8m platform height make these machines suitable for a wide range of requirements.

- Upgraded and reinforced design delivers better performance for various harsh conditions.
- The simple and reliable hydraulic system offers better on productivity.
- Swing out component trays for easy access and maintenance.
- CAN bus system and intelligent self-diagnostic system for quick troubleshooting.
- Commonality in key parts with other scissor lifts.



LGMG Hydraulic Motor Drive Scissor Lift

SPECIFICATIONS

MODELS	AS0812 (AS2646)		AS1012 (AS3246)		AS1212 (AS4046)	
Measurements	Metric	US	Metric	US	Metric	US
Working Height Max.	10m	32.8ft	12m	39.4ft	14m	46ft
A Platform Height-Raised	8m	26.2ft	10m	32.8ft	12m	39.4ft
B Platform Height-Stowed	1m	3.4ft	1.2m	3.9ft	1.3m	4.3ft
C Platform Length	2.26m	7.4ft	2.26m	7.4ft	2.26m	7.4ft
D Platform Width	1.15m	3.8ft	1.15m	3.8ft	1.15m	3.8ft
E Overall Length(with ladder)	2.42m	8ft	2.47m	8ft	2.47m	8ft
F Overall Width	1.18m	3.9ft	1.18m	3.9ft	1.18m	3.9ft
G Overall Height-Rails Up	2.3m	7.5ft	2.43m	8ft	2.56m	8.4ft
Overall Height-Rails Down	1.73m	5.7ft	1.86m	6.1ft	1.99m	6.5ft
H Extension Deck	0.9m	3ft	0.9m	3ft	0.9m	3ft
I Wheelbase	1.85m	73in	1.85m	73in	1.85m	73in
Ground Clearance(Stowed/Raised)	100/20mm	3.94/0.79in	100/20mm	3.94/0.79in	100/20mm	3.94/0.79in
PRODUCTIVITY						
Platform Occupants Max.(in/out)	2/1	2/1	2/1	2/1	2/0	2/0
Platform Capacity	450kg	990lbs	320kg	705lbs	320kg	705lbs
Platform Capacity-Extension	120kg	265lbs	120kg	265lbs	120kg	265lbs
Drive Height			Full Height			
Gradeability-Stowed			25 %			
Turning Radius-Inside			0			
Turning Radius-Outside	2.3m	7.5ft	2.3m	7.5ft	2.3m	7.5ft
Raise/Lower Speed	35/40 s		58/48 s		65/60 s	
Brakes			Front-wheel Brake			
Drive Mode			4×2			
Tires Type			Solid Non-marking			
Tires Size	380×130mm 15×5 in		380×130mm 15×5 in		380×130mm 15×5 in	
POWER						
Power Source	24V DC 240Ah		24V DC 240Ah		24V DC 300Ah	
HYDRAULIC SYSTEM						
Hydraulic Oil Capacity	16L	4.2gal	23L	6.1gal	23L	6.1gal
WEIGHT						
Machine Weight(CE/ANSI)	2360kg	5203lbs	3000kg	6614lbs	3160kg	6967lbs

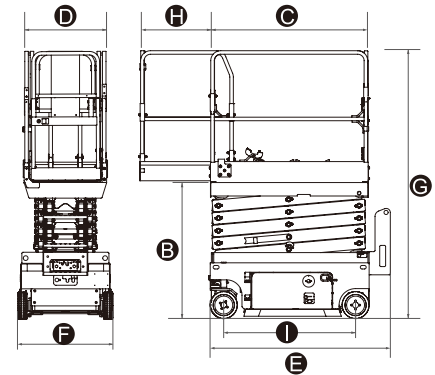

STANDARD FEATURES

- Proportional control
- Foldable guardrail
- Emergency stop device
- Manual brake release
- Emergency descent
- Swing-out component tray
- Pothole guard
- Self-lock entry gate
- Tilt alarm with lift cut-out
- Overload sensing system
- Descent alarm with flashing beacon
- Horn/Hour meter
- All motions alarm
- Full-height drive
- Intelligent diagnostic system

OPTIONAL

- AC power to platform
- Platform anti-collision device
- Air tube to platform
- Maintenance-free battery
- Lithium battery
- GPS

Machines in compliant with EN280 / ANSI 92.20 Standard.

Specifications subject to change without notice. Photos and diagrams in the page are for promotional purposes only.
2020 V1 Version

LINGONG GROUP JINAN HEAVY MACHINERY CO., LTD.

Address: No. 2676, Kejia Road, Jinan, Shandong, China
Email: sales@lgmg.com.cn Tel: +86-0531-67879283

LGMG Europe B.V.

Address: Laanweg 16 3208LC Spijkenisse Rotterdam, The Netherlands

LGMG North America, Inc.

Address: 1445 Sheffler Dr, Chambersburg, PA. 17201, USA



RELIABILITY IN ACTION